

# INSTALLATION INSTRUCTIONS

## TG SERIES

### Toxic Gas Sensor

### BACnet/Modbus/Analog



## ! WARNING

- Use installation wires rated for 75°C and above.
- Only qualified trade installers should install, program, maintain and test system incorporated therein. Installer is responsible for compliance of all applicable codes.
- Read, understand, and follow instructions thoroughly.
- The unit and associated systems require routine test and maintenance as prescribed in the TG Series User's Manual section 'Periodic Test and Maintenance'
- Do not install in hazardous or classified locations.
- De-energize power supply prior to installation.
- Gas sensors should not be used as a substitute for proper installation, use, or maintenance of gas emitting equipment.
- This device is designed to detect conditions that could result in acute effects of gas exposure. It will not fully safeguard individuals with specific medical conditions. If in doubt, consult a medical practitioner.
- Conduit is prone to condensation if it passes from one temperature zone to another, such as from indoors to outdoors or from one part of a building to another. This condensation may actually drip into the sensor if mounted below, causing damage and/or poor readings.

In order to prevent condensation and water egress, seal both the top and bottom of the conduit with a suitable expanding foam product (such as Polywater™ Zipseal™ ZIP-50KIT1) to prevent warm air from entering cold conduit.

Alternatively, fiberglass insulation may be inserted in the conduit between the cold and warm sections using a rigid wire or other method if both ends cannot be sealed. Sealing is the preferred method.

- Conduit air flow entering sensor may prevent sensor from reading ambient air properly, resulting in under measurement of gases. Plug sensor conduit in all installations with a foam plug or seal as noted above in order to prevent airflow from the conduit.

#### LIMITATION OF LIABILITY

Senva's liability, whether in contract, in tort, under any warranty, in negligence or otherwise shall not exceed the amount of the purchase price paid by the purchaser for the product. Under no circumstances shall Senva be liable for special or consequential damages.

<p><b>TGR -</b></p> <p><input type="checkbox"/></p> <p><b>Output Type</b> A = Analog B = BACnet/Modbus</p>	<p><input type="checkbox"/></p> <p><b>Gas Type 1</b> C = Carbon Monoxide (CO) D = Carbon Dioxide (CO<sub>2</sub>) E = Dual Channel CO<sub>2</sub> N = Nitrogen Dioxide (NO<sub>2</sub>) M = Methane (CH<sub>4</sub>) P = Propane (C<sub>3</sub>H<sub>8</sub>) H = Hydrogen (H<sub>2</sub>) O = Oxygen (O<sub>2</sub>) S = Hydrogen Sulfide (H<sub>2</sub>S) A = Ammonia 2 = R22* 3 = R134A* (Multi-Gas) 4 = R410A* 5 = R404A* 6 = R407C* 7 = R449A* 8 = R513A* 9 = 1233ZDE*</p>	<p><input type="checkbox"/></p> <p><b>Gas Type 2</b> X = No second gas D = Carbon Dioxide (CO<sub>2</sub>) E = Dual Channel (CO<sub>2</sub>) N = Nitrogen Dioxide (NO<sub>2</sub>) M = Methane (CH<sub>4</sub>) P = Propane (C<sub>3</sub>H<sub>8</sub>) H = Hydrogen (H<sub>2</sub>) O = Oxygen (O<sub>2</sub>) S = Hydrogen Sulfide (H<sub>2</sub>S) A = Ammonia</p>
--------------------------------------------------------------------------------------------------------------------	---------------------------------------------------------------------------------------------------------------------------------------------------------------------------------------------------------------------------------------------------------------------------------------------------------------------------------------------------------------------------------------------------------------------------------------------------------------------------------------------------------------------------------------------------------	----------------------------------------------------------------------------------------------------------------------------------------------------------------------------------------------------------------------------------------------------------------------------------------------------------------------------------------------------------------------------------------------------------------

\*Refrigerant gas sensors can ONLY be ordered as a stand-alone single element.

## FEATURES

The Senva TG Series sensor is a dual-sensor toxic gas detector. There are two versions to select from; the Analog version and the Communications version (BACnet MS/TP and Modbus RTU). Each version has Trouble and Alarm relays for controls/indication. The Analog version has two configurable 0-5V/10V or 4-20mA analog outputs that represent gas concentrations. The communications version has a physical RS-485 connection for communications over either BACnet MS/TP or Modbus RTU. These sensors can be mounted in an indoor application. In addition, each sensor has the following features:

**Visual/Audible Indicators** - LED indicator, audible alarm.

**Supports BACnet and Modbus (BACnet/Modbus Version)** - TG units with output type of BACnet/Modbus supports BACnet MS/TP and Modbus RTU.

**Dual Gas Monitoring** - Sensor can accommodate CO, NO<sub>2</sub>, CO<sub>2</sub>, Methane, Propane, Hydrogen, Oxygen, H<sub>2</sub>S, Ammonia, Refrigerants\* or a dual combination in one enclosure. Sensor can be expanded in field by adding additional elements.

\*Refrigerant sensors can only be ordered as standalone elements

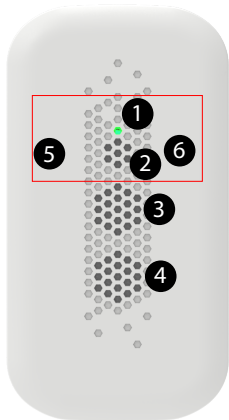

- 1 - LED indicator
- 2 - Buzzer
- 3 - Sensor Element 1
- 4 - Sensor Element 2
- 5 - Capacitive touch button
- 6 - Capacitive touch button
- - NFC Antenna

## NFC Setup

To change device settings that are not available through the dip switches, download the Senva Sensors app on your mobile phone. The NFC capabilities will give you access to the internal device settings.



## MOUNTING

### IF MOUNTING INTO A JUNCTION BOX:

1. Remove drywall clamps by turning screw counter clockwise.

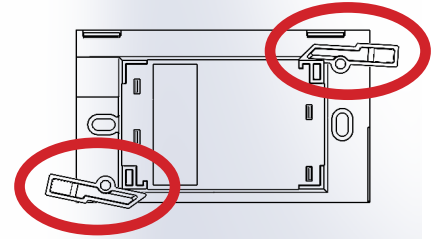

### IF MOUNTING INTO DRYWALL:

1. Turn both mounting clamps all the way counter clockwise.

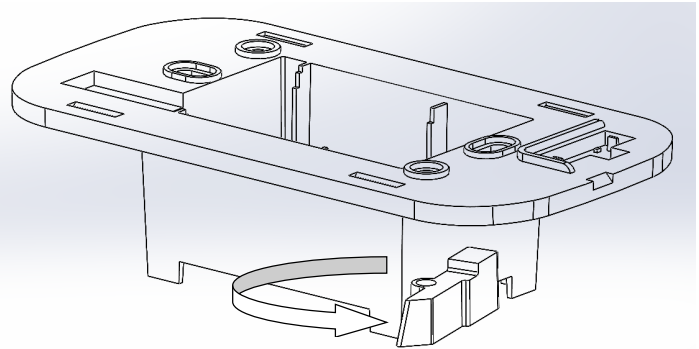

2. Insert into drywall cutout.

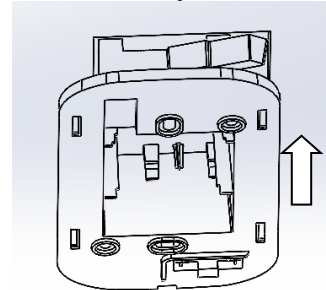

3. Turn screw clockwise to tighten drywall mounts until tight to wall.

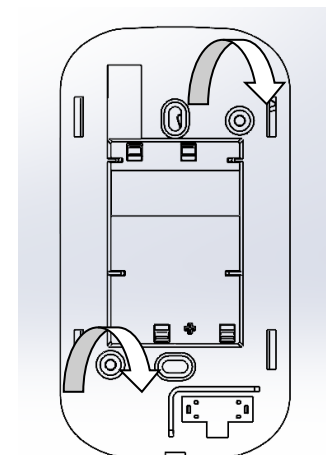

## WIRING CALL OUTS

### 3-WIRE 0-5/10V - 4-20mA

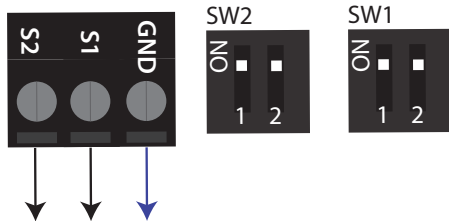
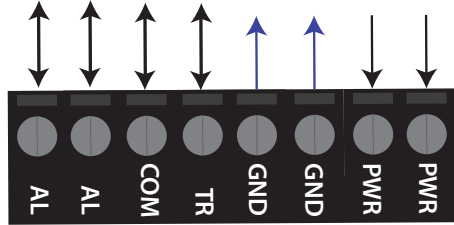

- PWR - Power
- PWR - Power
- GND - Common/Ground
- GND - Common/Ground
- TR - Trouble Relay
- COM - Relay Common
- AL - Alarm Relay
- AL - Alarm Relay
- S2 - Sensor 2 analog output
- S1 - Sensor 1 analog output
- GND - Common/Ground

### BACnet Comms Wiring

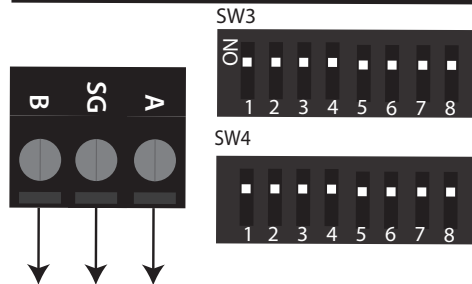
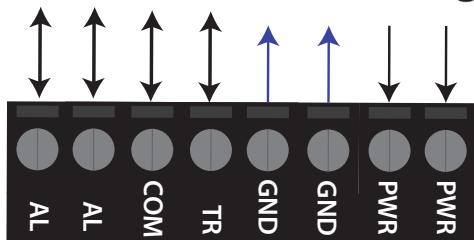

- PWR - Power
- PWR - Power
- GND - Common/Ground
- GND - Common/Ground
- TR - Trouble Relay
- COM - Relay Common
- AL - Alarm Relay
- AL - Alarm Relay
- B - -RS485(B(-))
- SG - Isolated Shield Ground
- A - +RS485(A(+))

## ANALOG SETUP

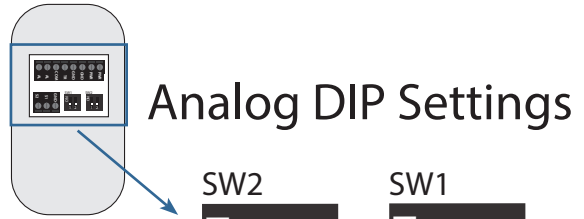

### Analog DIP Settings



SW2			SW1			
DIP	OFF	ON	DIP	Function	OFF	ON
1	Current	Voltage	1	<b>S1 Alarm</b>	LOW	HIGH
2	0-5V	0-10V	2	<b>S2 Alarm</b>	LOW	HIGH

## BACNET SETUP

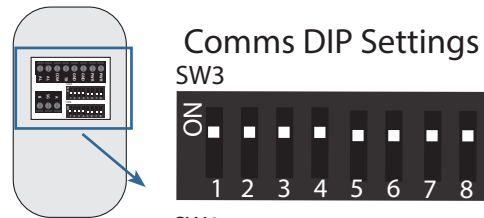

### Comms DIP Settings

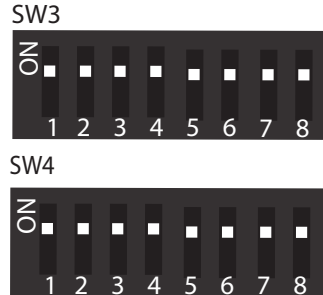

DIP	Function	OFF	ON
1	<b>MAC0</b>	0	1
2	<b>MAC1</b>	0	1
3	<b>MAC2</b>	0	1
4	<b>MAC3</b>	0	1
5	<b>MAC4</b>	0	1
6	<b>MAC5</b>	0	1
7	<b>MAC6</b>	0	1
8	<b>NO USE</b>		

DIP	Function	OFF	ON
1	<b>BAUD0</b>	N/A	120 OHM
2	<b>BAUD1</b>	0	1
3	<b>BAUD2</b>	0	1
4	<b>D/P/S0</b>	0	1
5	<b>D/P/S1</b>	0	1
6	<b>NO USE</b>		
7	<b>Protocol</b>	Modbus	BACnet
8	<b>EOL</b>	N/A	120 OHM

DIP	Function
SW3 1-7	<b>MAC Address/ Modbus Address</b> 0-127 (binary)
SW4 1-3	<b>Baud Rate</b> 0(00)=9600 1(001)=19200 2(010)=38400 3(011)=57600 4(100)=76800 5(101)=115200
SW4 4-5	<b>Data/Parity/Stp</b> 0(00)=8N1 1(01)=8N2 2(10)=8O1 3(11)=8E1

## WIRING AND INSTALLATION

1. For proper detector operation, ensure that the Senva TG is connected to a continuous source of power (not controlled by a wall switch). The TG current draw figures represent worst-case conditions and will not vary as the applied DC voltage varies. To meet the requirements of ANSI/UL 2075, Second Edition, the TG Carbon Monoxide detector employs duplicate power leads (Red and Black) where the first pair of power leads goes into the first Carbon Monoxide detector and the second pair of power leads goes to the next detector on the loop.
2. The alarm control panel zone inputs must be terminated with end of line resistors (E.O.L.R.), which are provided with the panel.
3. The relay of the TG is a dry contact and rated at 1A, 24VAC/30VDC. It shall not be used to directly drive a fan. When connecting the units to other UL approved devices, make sure that the load does not exceed the relay's rating.

## OPERATION

The following section details factory defaults for LED function, Trouble and alarm set-points, Trouble relay and alarm status functions, and the sensor element lifetime clock.

### LED Function

The LED indicators function in sync with the Trouble relay and alarm status thresholds. LED will change state if either of the gases reach their Trouble or alarm set-point.

Green	Normal readings below the low level set-point
Yellow	Gas concentration above the low level set-point and below the high level set-point
Red	Gas concentration level above the high level set-point

### Alarm Set-points

The alarm set-points are applicable for elements populated on the board by the factory, or added in the field by the user.

Sensor	LOW level (Default)	HIGH level (Default)
CO	35 ppm	100 ppm
NO2	1 ppm	3 ppm
CO2	800 ppm	5000 ppm
Methane/ Propane/ Hydrogen	10% L.E.L.	25% L.E.L.
Oxygen	Less than 19.5% Vol	Greater than 23% Vol
H2S	25 ppm	75 ppm
Ammonia	20 ppm	40 ppm
Refrigerants	300 ppm	600 ppm

### Trouble Signal

During a device failure mode the N.C. Trouble relay will open and the Device LED indicator will then turn yellow and blink to indicate one of the following events:

- Removal of a sensor
- Sensor is at end of life
- The pulse check function has detected a sensor failure
- The device has lost power

### CO for Fire Alarm System

The sensors shall respond with the following Carbon Monoxide concentration and time limits.

Single and multiple-station CO alarms (UL Product code: CZHF)	
Concentration of CO	Maximum Alarm time response
70-150 PPM	60 minutes
151-400 PPM	15 minutes
401-450 PPM	5 minutes
Above 450 PPM	Instant alarm

## PERIODIC TEST AND MAINTENANCE

### Periodic Maintenance

Though the frequency of inspection is typically affected by the operating conditions and environment (extreme temperatures, extreme humidity, exposure to contaminants, etc.), Senva recommends the following maintenance and intervals. More frequent maintenance may be required per local code by the Jurisdiction Having Authority (JHA). An accurate log of all maintenance and abnormal occurrences should be maintained for the proper service of this product

#### Every 6 Months

- For Methane, Propane, Hydrogen, H2S, Ammonia NH3 or refrigerants retest and recalibrate the unit using NIST traceable reference gas to ensure sensors remain accurate.
- Visually inspect to ensure optimal operating conditions (no broken pieces/components, sensor filter not blocked or discolored, visual indicators operational, etc.).
- Clean the exterior with a soft cloth to remove debris from the sensor intake ports.

#### Annual

- For Oxygen, CO or NO2, retest and recalibrate the unit using NIST traceable reference gas to ensure sensors remain accurate.
- For sensor replacement be sure to power down the sensor and remove element to be replaced and plug in new element in its place and then re-apply power.

#### Do Not

- Expose the sensor and its elements to solvents.
- Immerse the sensor into liquids.

# WIRING EXAMPLES

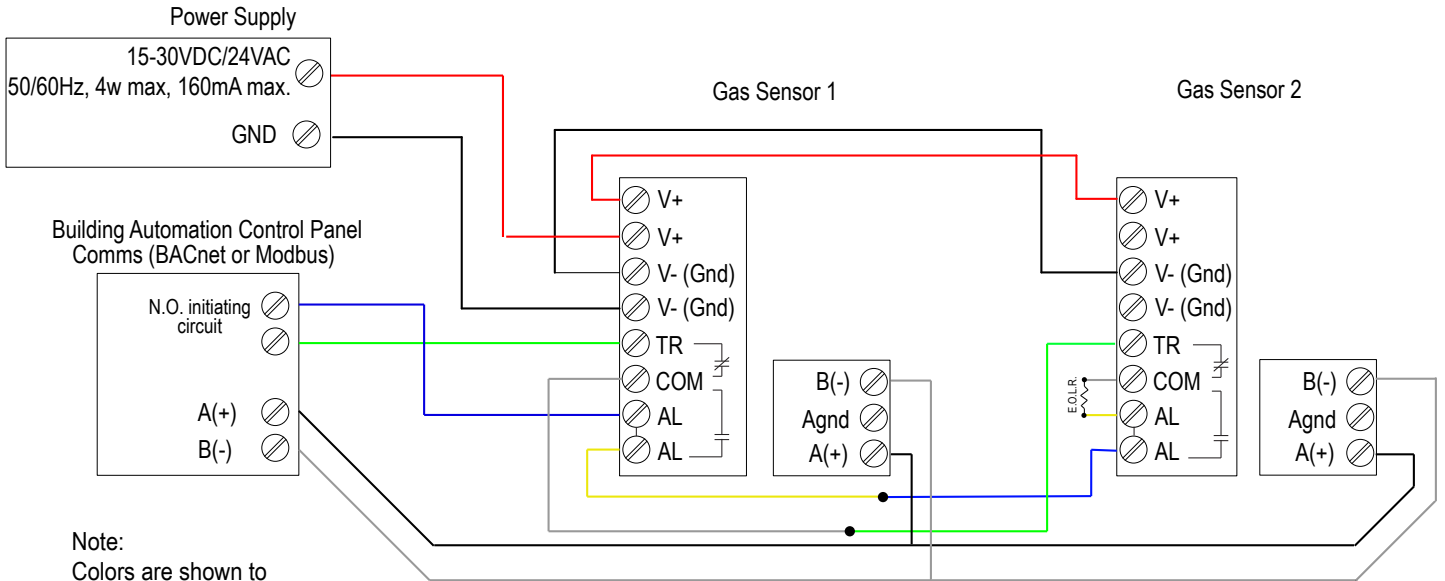

Note:  
Colors are shown to clarify node connections; wire color shall be determined by national and local electrical codes.

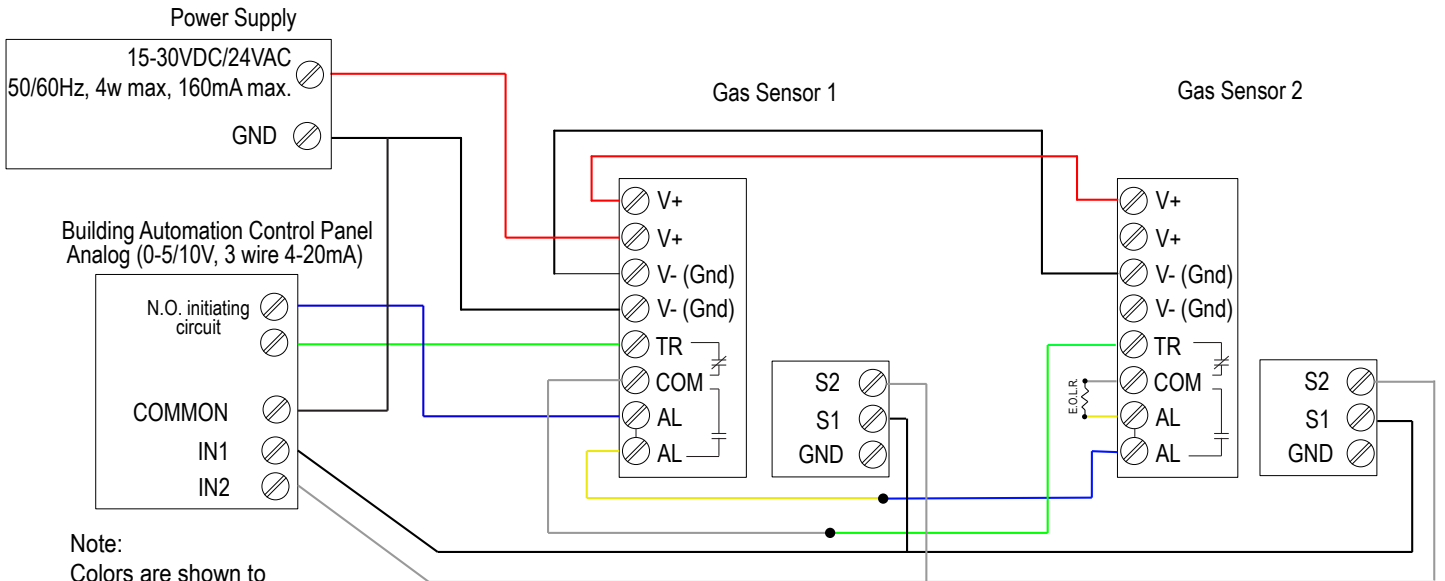

Note:  
Colors are shown to clarify node connections; wire color shall be determined by national and local electrical codes.

# SPECIFICATIONS

Power supply	<b>Comms</b>	16-30VDC/24VAC <sup>(1)</sup> , 5W max, 200mA max.
	<b>Analog</b>	12-30VDC/24VAC <sup>(1)</sup> , 5W max, 200mA max.
Wiring	<b>Conductor</b>	14-24 AWG, Minimum 600V, 75°C
	<b>Terminal Torque</b>	0.5 N·m
Outputs (Analog)	<b>2 Programmable Outputs</b>	0-10V (default), 0-5V, 4-20mA <sup>(2)</sup> (selectable)
	<b>CO Output Scaling</b>	0-200ppm (default), 0-500ppm (menu selectable)
	<b>NO<sub>2</sub> Output Scaling</b>	0-10ppm (default), 0-10ppm (menu selectable)
	<b>CO<sub>2</sub> Output Scaling</b>	0-10,000 ppm (default), 0-10,000 ppm (menu selectable)
	<b>Propane/Methane/Hydrogen Output Scaling</b>	0-50% LEL (default), 0-50% LEL (menu selectable)
	<b>Oxygen Output Scaling</b>	0-25% Vol (default), 0-25% Vol (menu selectable)
	<b>Refrigerant Output Scaling</b>	0-1000 ppm (default), 0-1000 ppm (menu selectable)
	<b>H<sub>2</sub>S Output Scaling</b>	0-100 ppm (default), 0-100 ppm (menu selectable)
	<b>Ammonia NH<sub>3</sub> Output Scaling</b>	0-100 ppm (default), 0-100 ppm (menu selectable)
	<b>Temp Output Scaling (optional)</b>	-20 to 85°C
Output (BACnet/Modbus)	<b>RS-485</b>	BACnet MS/TP, Modbus RTU, Modbus ASCII
	<b>Baud Rates</b>	9600, 19200, 38400, 57600, 76800, 115200
	<b>RS-485 Loading</b>	1/4 unit
Trouble Relay	<b>Trouble relay characteristics</b>	N.C. 1A@24VAC/30VDC(50/60Hz)(No Mains Connection)
Alarm Relay	<b>Alarm relay characteristics</b>	N.O. 1A@24VAC/30VDC(50/60Hz)(No Mains Connection)
LED's	<b>Green, Yellow, Red</b>	Green = Normal, Yellow = Relay, Red = Alarm
Audible exposure alarm	<b>85dB@4" Piezo transducer</b>	30 minutes above alarm set-point per UL2034 (menu selectable)
CO Sensor Performance <sup>(3)</sup>	<b>Type</b>	Electrochemical
	<b>Accuracy</b>	±5% of Default Range, ± 5% of Reading Above 200ppm
	<b>Resolution</b>	1ppm
	<b>Life expectancy</b>	7 years
	<b>Recommended Calibration</b>	Annual
	<b>Recommended Height<sup>(4)</sup></b>	3 to 6 feet; coverage 5000-7500 sq ft.
NO <sub>2</sub> Sensor Performance <sup>(4)</sup>	<b>Type</b>	Electrochemical
	<b>Accuracy</b>	±5% of Default Range, ± 5% of Reading Above 20ppm
	<b>Resolution</b>	0.1ppm
	<b>Life expectancy</b>	7years
	<b>Recommended Calibration</b>	Annual
	<b>Recommended Height</b>	3 to 6 feet; coverage 5000-7500 sq ft.
CO <sub>2</sub> Sensor Performance	<b>Type</b>	Non-dispersive Infrared (NDIR)
	<b>Accuracy <sup>(5)</sup></b>	±(30ppm +3% of reading) (400-2000ppm), @-10-50°C ±(50ppm +5% of reading) Standard (2000-5000ppm), @-10-50°C ±(50ppm+3% of reading) Dual Channel (2000-5000ppm), @-10-50°C ±(100ppm+10% of reading) (5000-10000ppm), @ 0-50C
	<b>Drift with ABC disabled<sup>(6)</sup></b>	35ppm/month <sup>(6)</sup> (Standard) 5ppm/month <sup>(6)</sup> (Dual Channel)
	<b>Range</b>	0-2000/5000ppm; Programmable up to 10,000ppm
	<b>Response time</b>	30s
	<b>Sample rate</b>	1s
	<b>Recommended Height</b>	3 to 6 feet; coverage 5000-7500 sq ft.

(1) One side of transformer secondary is connected to signal common. Dedicated transformer is recommended. No mains circuit connection allowed. In addition, it is required to use an isolated power supply that is certified by a national or international standard (i.e. UL). Use of a Class 2 LPS power supply or greater is required.

(2) Extreme temperatures may affect accuracy when using 4-20mA outputs.

(3) Carbon Monoxide full scale is 1000 ppm.

(4) Nitrogen Dioxide full scale is 30 ppm.

(5) Accuracy of CO<sub>2</sub> reading may be reduced at temperatures below 14°F (-10°C).

(6) It is not recommended to de-activate ABC (auto-calibration) except for continuously occupied spaces or greenhouses. Drift ratings may vary based on environment.

## SPECIFICATIONS (Continued)

Methane/Propane/ Hydrogen Sensor Performance	Type	Catalytic
	Detection Range	0-50% LEL (Lower Explosive Limit)
	Accuracy	±5% of Range
	Resolution	1% LEL
	Life expectancy	5 years
	Recommended Calibration	6 months
	Recommended Height <sup>(7)</sup>	Hydrogen/Methane: 0.5 to 1 foot from ceiling; coverage 5000-7500 sq ft
Oxygen Sensor Performance	Type	Electrochemical
	Detection Range	0-25% Volume
	Accuracy	±5% of Range
	Resolution	0.1%
	Life expectancy	5 years
	Recommended Calibration	Annual
	Recommended Height	3 to 6 feet; coverage 5000-7500 sq ft.
H2S Sensor Performance	Type	Electrochemical
	Detection Range	0-100 ppm
	Accuracy	±5% of Range
	Resolution	1 ppm
	Life expectancy	5 years
	Recommended Calibration	6 months
	Recommended Height	3 to 6 feet; coverage 5000-7500 sq ft.
Ammonia NH3 Sensor Performance	Type	Electrochemical
	Detection Range	0-100 ppm
	Accuracy	±5% of Range
	Resolution	0.1 ppm
	Life expectancy	5 years
	Recommended Calibration	6 months
	Recommended Height	0.5 to 1 foot from ceiling; coverage 5000-7500 sq ft.
Refrigerant Sensors Performance	Type	MOS
	Detection Range	0-1000 ppm
	Resolution	1 ppm
	R22, R134A, R410A, R404A, R407C	Calibrated for respective gas
	R134A Sensitivity <sup>(8)</sup>	@300ppm test gas: 450 ppm R410A, 425 ppm R407C, 400 ppm R404A, 370 ppm R22, 300 ppm R134A
	Life expectancy	10 years (typical expectation for MOS sensors)
	Recommended Calibration	6 months
Recommended Height	6 inches above floor; no more than 18 inches above lowest level of equipment location for leak detection; coverage 5000-7500 sq ft.	
Operating Environment	Temperature, continuous	-20 to 50°C
	Humidity	15-90% continuous, 0-99% intermittent
	Max Elevation	2000m
Enclosure	Material	ABS/Polycarbonate
	Rating	IP20
	Dimensions	5.66" h x 3.0" w x 1.69" d
Agency	Compliance	CE

(7) Combination CO/Methane, CO/Propane, or CO/Refrigerant sensors should be mounted according to Propane/Methane/Refrigerant recommendations. Consult factory for other combinations. Mounting height recommendations may be adjusted according to installation. Ensure sensor is accessible for maintenance and target gas has unobstructed access to sensor. Mount in accordance with ANSI/NFPA 70 and NEC or CEC.

(8) R134A sensor may be used as a general purpose refrigerant detection. The sensor's response to other refrigerants will change proportionally as shown in the following app note: <https://www.senvainc.com/catalog/documents/downloadcenter/Refrigerant%20cross%20sensitivities.pdf> (or scan QR code). Actual response may vary depending on installation. For more accurate response to a specific gas, a unit may be field calibrated.



## TROUBLESHOOTING

Symptom	Solution
No output	Check wiring. Ensure power supply meets requirements.
Sensor reading error	Sensor contaminated or at end of life. Replace sensor.
Relay Function	Verify set-point. Verify test gas concentration. Cover sensor to prevent drafts and dilution during test.

### BACnet/Modbus Quick Reference

The following section outlines some commonly utilized Modbus registers and BACnet objects for quick reference. For a complete list and description of each, please see the associated protocol guides: *TGR BACnet Protocol Guide* or *TGR Modbus Protocol Guide*.

#### Access Legend:

- R=Readable
- W=Write-able
- W0 = Write-able with 0 only
- NV = Saved in non-volatile configuration memory

Description	BACnet Object	Modbus Register	Access
Gas 1 Concentration	AI1	1	R/W0
Gas 2 Concentration	AI9	16	R/W0
Gas 1 Warning Set-point	AV4	101	R/W/NV
Gas 1 Alarm Set-point	AV5	102	R/W/NV
Gas 2 Warning Set-point	AV14	105	R/W/NV
Gas 2 Alarm Set-point	AV15	106	R/W/NV

#### Supported Modbus Functions:

- 0x03 Read Multiple Holding Registers
- 0x04 Read Register Input
- 0x06 Write Single Register
- 0x10 Write multiple Registers

### DIMENSIONS

